

Centre Number	Candidate Number	Name
---------------	------------------	------

CAMBRIDGE INTERNATIONAL EXAMINATIONS
General Certificate of Education Ordinary Level

CHEMISTRY

5070/02

Paper 2 Theory

May/June 2003

1 hour 30 minutes

Candidates answer on the Question Paper.
Additional Materials: Answer Paper

READ THESE INSTRUCTIONS FIRST

Write your name, Centre number and candidate number in the spaces at the top of this page and on any separate answer paper used.

Sections A

Answer **all** questions.

Write your answers in the spaces provided on the question paper.

Section B

Answer any **three** questions.

Write your answers on the separate answer paper.

At the end of the examination, fasten any separate answer paper used securely to the question paper.

The number of marks is given in brackets [] at the end of each question or part question.

A copy of the Periodic Table is printed on page 16.

If you have been given a label, look at the details. If any details are incorrect or missing, please fill in your correct details in the space given at the top of this page.

Stick your personal label here, if provided.

For Examiner's Use	
Section A	
B8	
B9	
B10	
B11	
TOTAL	

This document consists of **14** printed pages and **2** blank pages.



Section A

Answer **all** the questions in this section in the spaces provided.

A1 Choose from the following elements to answer the questions below.

argon bromine carbon hydrogen
iodine iron neon sulphur

Each element can be use used once, more than once, or not at all.

Name an element which

(a) forms a basic oxide,

.....[1]

(b) is a liquid at room temperature and pressure,

.....[1]

(c) reacts with aqueous copper(II) sulphate to give a pink solid,

.....[1]

(d) is formed during the electrolysis of concentrated aqueous sodium chloride,

.....[1]

(e) has a giant molecular structure.

.....[1]

A2 Ethanol, $\text{CH}_3\text{CH}_2\text{OH}$, is a liquid fuel. Ethanol can be manufactured either from glucose, $\text{C}_6\text{H}_{12}\text{O}_6$, or from ethene.

(a) Briefly describe the manufacture of ethanol from glucose.
Include the balanced equation in your answer.

.....
.....
.....
.....[4]

(b) (i) Draw the displayed formula for ethene.

(ii) Name the substance that reacts with ethene to make ethanol.

.....

(iii) Give the conditions needed for this reaction.

.....
.....

[4]

A3 Petroleum is a complex mixture of hydrocarbons. Petroleum is a source of many useful fuels.

(a) What is meant by the term *hydrocarbon*?

.....
[1]

(b) Petroleum is separated by fractional distillation.

(i) Complete the following table about the fractions obtained from petroleum.

fraction	use
petrol (gasoline)	fuel for cars
paraffin (kerosene)	
diesel	fuel for diesel engines
bitumen	

(ii) Name one **other** fraction obtained from petroleum.

.....
 [3]

(c) Fractional distillation of petroleum does not produce sufficient of some fractions to match demand.

Cracking is used to convert large hydrocarbon molecules into smaller molecules that are more in demand.

A hydrocarbon of molecular formula $C_{12}H_{26}$ is cracked.

(i) Suggest the formula of one **alkane** that may be produced.

.....

(ii) Suggest the formula of one **alkene** that may be produced.

.....

(iii) Describe a chemical test that can be used to distinguish between an alkene and an alkane.

chemical test

result with alkane

result with alkene

[4]

- A4** Carbon dioxide is a greenhouse gas. Carbon dioxide is given a greenhouse factor of 1. Other gases are given a greenhouse factor that compares their effect with carbon dioxide. The greenhouse effect increases as the factor value increases. The table gives some information about four different gases.

gas	greenhouse factor	percentage of gas in the atmosphere
CO ₂	1	0.036
CH ₄	30	0.0017
N ₂ O	160	3.0×10^{-4}
CCl ₃ F	21000	2.8×10^{-8}

- (a) State **one** possible consequence of an increased greenhouse effect.
[1]
- (b) Give **one** source of methane.
[1]
- (c) Why is an increase in the percentage of methane more worrying than the same percentage increase of carbon dioxide?

[1]
- (d) What other environmental problem, beside its action as a greenhouse gas, is caused by CCl₃F?
[1]

A5 Marble statues are being damaged by acid rain. The chemical name for marble is calcium carbonate.

A student investigated the reaction between marble chips and nitric acid.

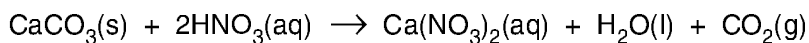

The diagram shows the apparatus the student used.

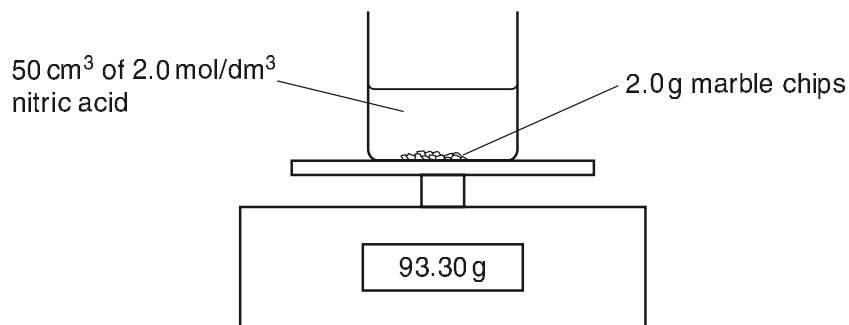

The student recorded the balance reading every minute.

The table shows the results.

time / minutes	balance reading / g
0	93.30
1	93.28
2	93.26
3	93.24
4	93.22
5	93.21
6	93.20
7	93.19
8	93.18
9	93.17
10	93.16
11	93.15
12	93.15
13	93.14
14	93.14

(a) Explain why the balance reading decreases during the experiment.

.....
[1]

(b) How can the student tell when the reaction has finished?

.....
[1]

(c) (i) Calculate the number of moles of nitric acid in 50 cm³ of 2.0 mol/ dm³ solution.

(ii) Calculate the number of moles of calcium carbonate in 2.0 g.

(iii) Which reagent, calcium carbonate or nitric acid, is in excess?
Explain your answer.

[5]

(d) The student repeats the experiment using the same quantities of calcium carbonate and nitric acid. This time the acid is at a higher temperature. Describe and explain, in terms of collisions between reacting particles, the effect of increasing the temperature on the rate of reaction.

.....
.....
.....[2]

A6 A student adds aqueous sodium hydroxide from a burette into 25.0 cm³ of dilute sulphuric acid. The student measures the pH value of the mixture during the addition of the sodium hydroxide.

(a) Describe how the pH value changes.

.....[1]

(b) Give an ionic equation to represent the neutralisation reaction between sodium hydroxide and sulphuric acid.

.....[1]

(c) Sulphuric acid is a strong acid.

(i) What is meant by the term *acid*?

.....
.....

(ii) What is the difference between a strong acid and a weak acid?

.....
.....
.....
.....[3]

(d) Dilute sulphuric acid reacts with magnesium to give hydrogen.
Give the ionic equation for this reaction.

.....[1]

A7 The structures of two ionic lattices are shown below.

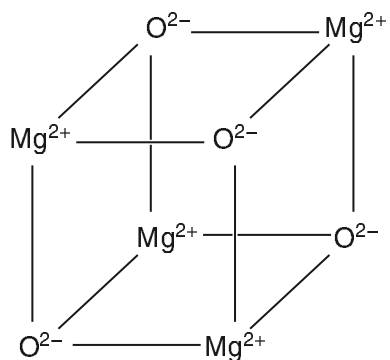

magnesium oxide

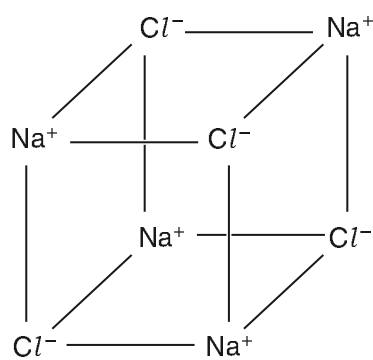

sodium chloride

(a) Explain why these two solids do not conduct electricity.

.....
[1]

(b) (i) Explain why magnesium oxide has a very high melting point.

.....

(ii) Suggest why the melting point of magnesium oxide is much higher than that of sodium chloride.

.....

 [2]

(c) Draw the electronic structure of a magnesium ion and of an oxide ion.

magnesium ion

oxide ion

[2]

Section B

Answer **three** questions from this section.

- B8** The NASA space shuttle uses fuel cells to generate electricity. The diagram below shows a hydrogen-oxygen fuel cell.

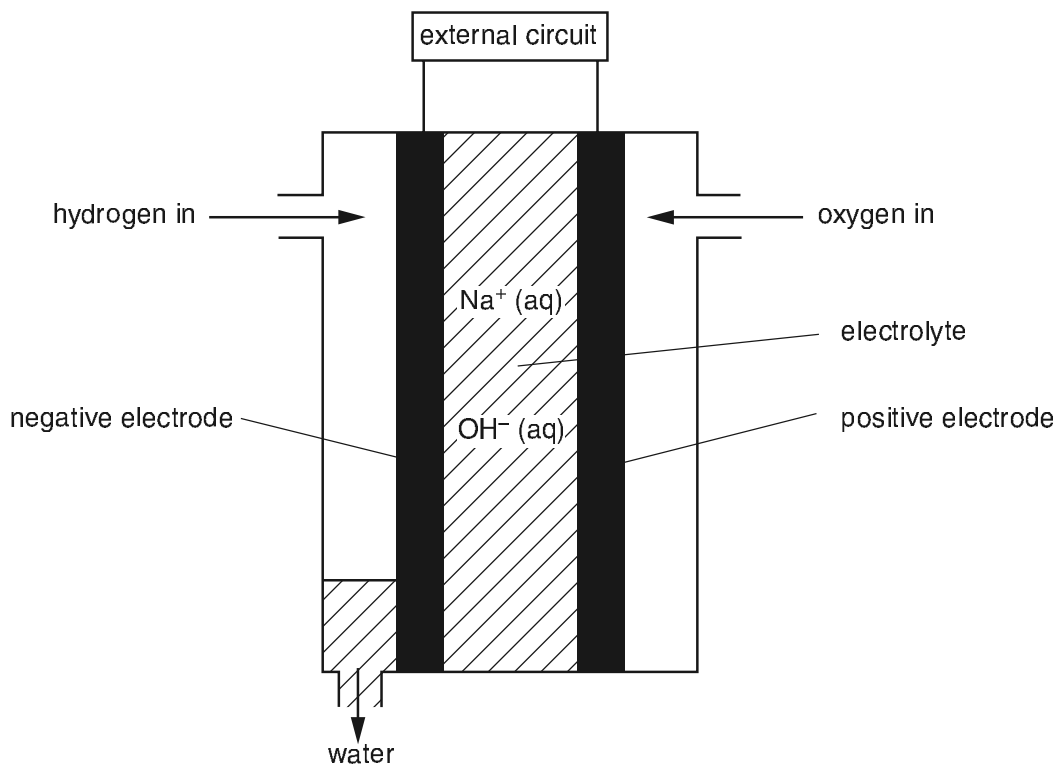

At the positive electrode, oxygen reacts with water as shown.

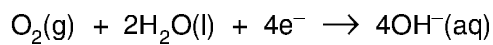

At the negative electrode, hydrogen reacts with hydroxide ions as shown.

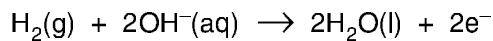

The overall reaction in the fuel cell is the reaction between hydrogen and oxygen to make water.

- (a) Give **one** source for hydrogen and **one** source for oxygen for use in a fuel cell. [2]
- (b) What is the name of the electrolyte used in the fuel cell? [1]
- (c) What type of reaction takes place, reduction or oxidation, at the positive electrode? Explain your answer. [1]
- (d) A fuel cell uses 240 dm³ of hydrogen. Calculate the volume of oxygen needed, and the mass of water formed. All gas volumes measured at room temperature and pressure. [3]
- (e) Describe some advantages and disadvantages of using a fuel cell to generate electricity. [3]

B9 The table gives information about the first five members of the homologous series of carboxylic acids.

name of acid	formula	relative molecular mass	melting point / °C	boiling point / °C
methanoic acid	HCO_2H	46	8.4	101
ethanoic acid	$\text{CH}_3\text{CO}_2\text{H}$	60	17	118
propanoic acid	$\text{C}_2\text{H}_5\text{CO}_2\text{H}$	74	-22	141
butanoic acid	$\text{C}_3\text{H}_7\text{CO}_2\text{H}$	88	-8	164
pentanoic acid				

- (a) (i) Predict the formula and the relative molecular mass for pentanoic acid.
(ii) Explain why it is easier to predict the boiling point of pentanoic acid than the melting point. [3]
- (b) Draw the displayed formula for propanoic acid. [1]
- (c) Analysis of an organic acid isolated from red ants shows that it contains 0.060 g of carbon, 0.010 g of hydrogen and 0.16 g of oxygen.
Calculate the empirical formula for this acid. [2]
- (d) Ethanoic acid reacts with magnesium oxide.
Name the products formed and write a balanced equation for the reaction. [2]
- (e) Describe how ethanoic acid can be converted into ethyl ethanoate. [2]

B10 Methane, CH₄, is used as a fuel. The complete combustion of methane can be represented by the equation below.

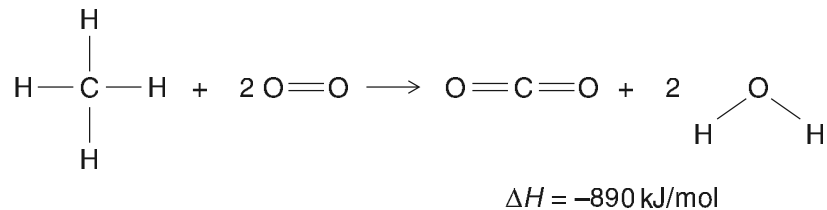

- (a) Explain why this reaction is exothermic in terms of the energy changes that take place during bond breaking and bond making. [3]
- (b) Calculate the energy released when 4.0 g of methane is completely combusted. [2]
- (c) Draw the energy profile diagram for the complete combustion of methane. Label on the diagram the activation energy and the enthalpy change. [3]
- (d) Draw a 'dot and cross' diagram to show the bonding in methane. You only need to draw the outer (valence) electrons of carbon. [2]

B11 Coal-burning power stations produce sulphur dioxide and oxides of nitrogen. These two gases cause acid rain.

- (a) Nitric oxide, NO, is made in a power station when nitrogen and oxygen react together. Write the equation for this reaction. [1]
- (b) Many coal burning power stations are now fitted with a flue gas desulphurisation plant which removes sulphur dioxide and nitrogen dioxide from the gaseous emissions.

In a flue gas desulphurisation plant, powdered calcium carbonate reacts with sulphur dioxide as shown.

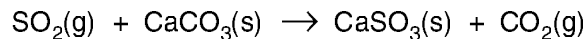

- (i) Suggest why the calcium carbonate is powdered. [1]
- (ii) Calculate the mass of calcium carbonate needed to react with 8000 kg of sulphur dioxide. [3]
- (iii) Nitrogen dioxide also reacts with calcium carbonate. Suggest the name of the solid product of this reaction. [1]
- (c) In the air sulphur dioxide reacts with nitrogen dioxide forming sulphur trioxide. The reactions that take place are shown in the equations.

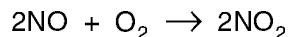
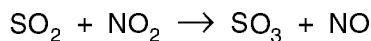

Suggest the role of nitrogen dioxide in these reactions. Explain your answer. [2]

- (d) Sulphur dioxide is used in the Contact process to make sulphuric acid. Describe the conditions and name the catalyst in the Contact process. [2]

