

CAMBRIDGE INTERNATIONAL EXAMINATIONS
General Certificate of Education Ordinary Level
PHYSICS
PAPER 3 Practical Test

5054/3

MAY/JUNE SESSION 2002
2 hours

Additional materials:
As specified in Instructions to Supervisors
Graph paper

TIME 2 hours

INSTRUCTIONS TO CANDIDATES

Write your name, Centre number and candidate number in the spaces provided on the answer booklet.
Answer **all** questions.

Write your answers in the spaces provided in the answer booklet.

For each of the questions in Section A, you will be allowed to work with the apparatus for a maximum of 20 minutes. For the question in Section B, you will be allowed to work with the apparatus for a maximum of 1 hour.

You are expected to record all your observations as soon as these observations are made. All of your answers should be written in the answer booklet; scrap paper must **not** be used.

An account of the method of carrying out the experiments is **not** required.

At the end of the examination, hand in only the answer booklet.

INFORMATION FOR CANDIDATES

Graph paper is provided in the enclosed answer booklet. Additional sheets of graph paper should be used only if it is necessary to do so.

Any additional sheets should be attached firmly to the answer booklet.

This question paper consists of 6 printed pages, 2 blank pages and an inserted answer booklet.



Section A

Answer **all** questions in this section.

- 1 In this experiment, you will determine the tension T in a horizontal length of string.

You have been provided with a newton meter, some string, a mass hanger, a range of slotted masses, a metre rule and a set square. The apparatus has been set up as shown in Fig. 1.1.

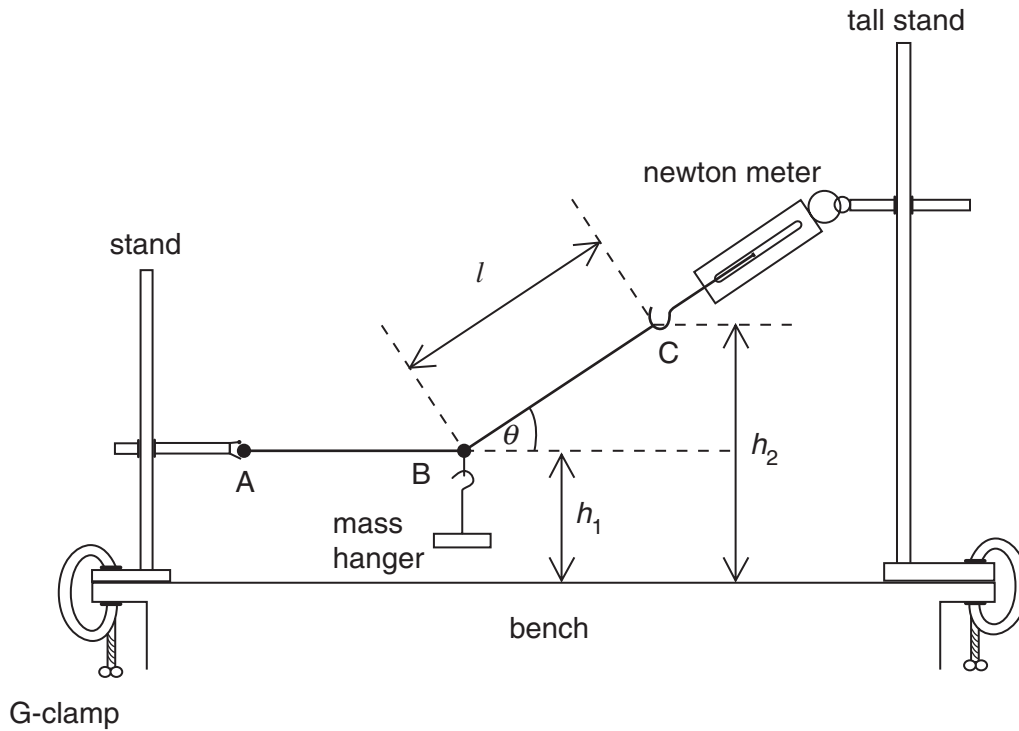

Fig. 1.1

- (a) Suspend a total mass M of 0.400 kg from the point B on the string by adding slotted masses to the mass hanger. Adjust the height of the clamp holding the newton meter until the string AB is horizontal.
- (b) Record in your answer booklet
- (i) the reading of the force F on the newton meter,
 - (ii) the heights h_1 and h_2 of the points B and C above the bench,
 - (iii) the length l of the section BC of the string.
- (c) Explain
- (i) how you ensured that the section AB of the string was horizontal,
 - (ii) how the heights h_1 and h_2 were measured accurately.

- (d) Calculate the angle θ between the section BC of the string and the horizontal, given that

$$\sin \theta = \frac{h_2 - h_1}{l}.$$

- (e) The three forces acting on the point B are in equilibrium and may be represented by the sides of the triangle shown in Fig. 1.2.

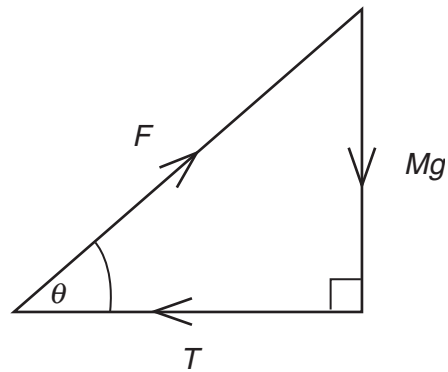

Fig. 1.2

The weight Mg is 4.0 N.

Draw a scale diagram of the forces using a scale of 1 cm = 1 N and hence find the tension T .

2 In this experiment, you will estimate the power produced by a candle flame.

You have been provided with a candle, a 100 ml (cm^3) glass beaker, a supply of water, a thermometer, a stopwatch, a stirrer, a stand and two clamps and bosses. You have access to a top pan balance.

- (a) Measure and record, on page 3 of your answer booklet, the mass m_B of the empty 100 cm^3 beaker. Half fill the beaker with water. Determine the mass m_W of the water in the beaker.
- (b) Set up the apparatus as shown in Fig. 2.1. Record the temperature θ_1 of the water in the beaker.

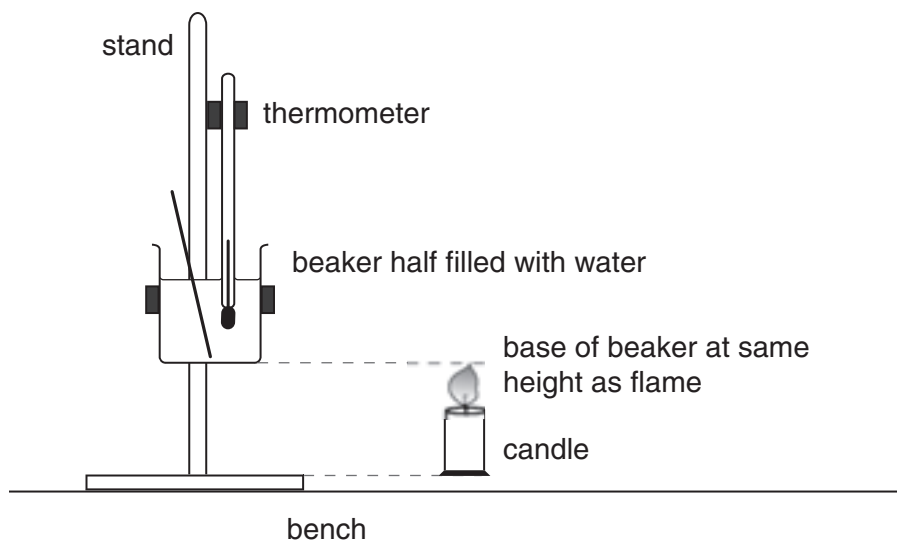

Fig. 2.1

- (c) Light the candle away from the beaker. Adjust the height of the beaker so that its base is at the same height as the top of the candle flame. Carefully place the lit candle under the base of the beaker and at the same time start the stopwatch. After two minutes remove the candle from under the beaker and record the highest temperature θ_2 reached by the water in the beaker.
- (d) Calculate the heat energy Q gained by the water and beaker, given that
- $$Q = m_W c_W (\theta_2 - \theta_1) + m_B c_B (\theta_2 - \theta_1)$$
- where c_W = specific heat capacity of water = $4.2 \text{ J}/(\text{g } ^\circ\text{C})$
and c_B = specific heat capacity of glass = $0.67 \text{ J}/(\text{g } ^\circ\text{C})$.
- (e) Calculate the power supplied by the candle, given that power = energy/time.
- (f) State one assumption made in your calculations.

- 3 In this experiment, you will determine the voltage across two resistors in order to determine their resistance values.

You have been provided with a power supply, a switch, an ammeter, two resistors whose values are concealed, a voltmeter and connecting leads.

- (a) The circuit has already been set up by the Supervisor as shown in Fig. 3.1.

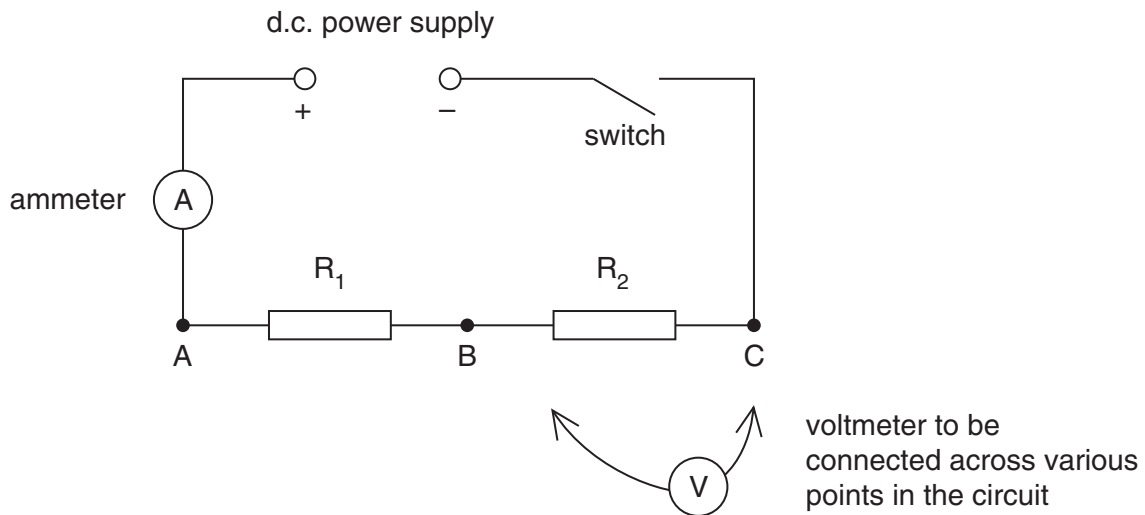

Fig. 3.1

- (b) Close the switch and then, by connecting the voltmeter across the points indicated, record the following voltages:
- the voltage V_{AB} between points A and B,
 - the voltage V_{BC} between points B and C,
 - the voltage V_{AC} between points A and C.
- (c) Comment on the results you have obtained in (b).
- (d) Record the current I in the circuit. Switch off when you have recorded the current.
- (e) Calculate the resistances of the resistors R_1 and R_2 , using the relationship

$$\text{resistance} = \frac{\text{voltage}}{\text{current}} .$$

Section B

- 4 In this experiment, you will investigate the magnification produced by a converging lens.

You have been provided with a light source, an object, a converging lens in a holder, a screen with a grid on it and a metre rule.

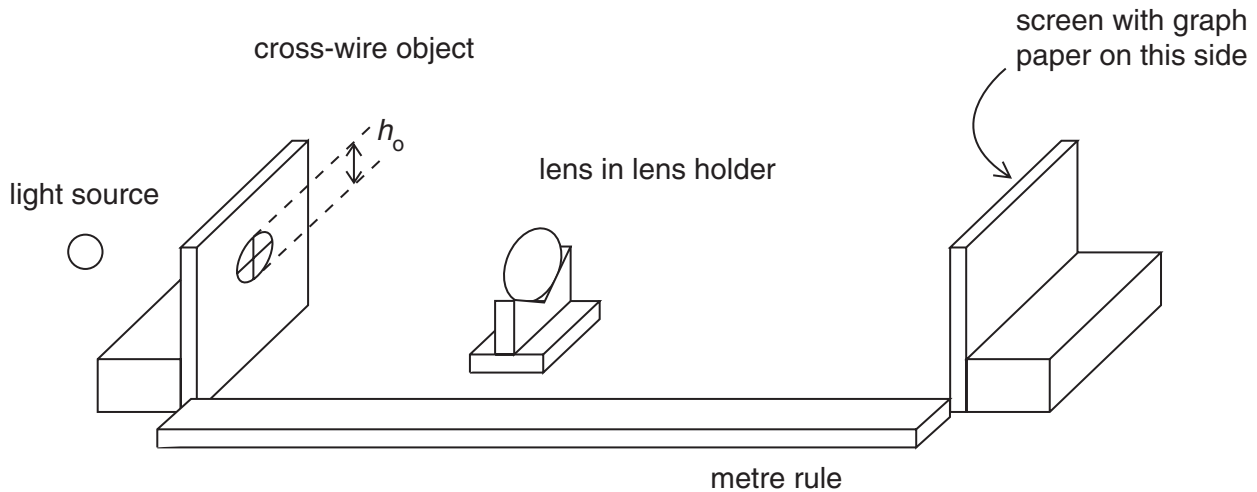

Fig. 4.1

- (a) Record the height h_o of the object.
- (b) (i) Set up the apparatus as shown in Fig. 4.1 with the screen 100 cm from the object.
 (ii) Adjust the distance of the lens from the screen until a sharply focused **magnified** image of the object is formed on the screen.
 (iii) The image is inverted. Explain how you would demonstrate this experimentally.
- (c) Record
- (i) the distance v between the lens and the screen,
 (ii) the height h_I of the image on the screen.
- (d) Calculate the linear magnification m of the image, given that
- $$m = \frac{h_I}{h_o}.$$
- (e) Repeat parts (b)(ii), (c) and (d) for different distances between the object and the screen. These distances should be between about 65 cm and 100 cm. You should only use **magnified** images of the object. Tabulate all your results on page 6 of your answer booklet, including values of v , h_I and m .
- (f) Using the grid on page 7 of your answer booklet, plot a graph of m against v/cm .
- (g) Find the gradient G of your graph.
- (h) Determine focal length f of the lens in cm. This is given by $f = 1/G$.

