



UNIVERSITY OF CAMBRIDGE INTERNATIONAL EXAMINATIONS  
General Certificate of Education Ordinary Level

CANDIDATE  
NAME

CENTRE  
NUMBER

--	--	--	--	--

CANDIDATE  
NUMBER

--	--	--	--

**PHYSICS**

**5054/03**

Paper 3 Practical Test

**October/November 2009**

**2 hours**

Candidates answer on the Question Paper.

Additional Materials: As listed in the Confidential Instructions

**READ THESE INSTRUCTIONS FIRST**

Write your Centre number, candidate number and name on all the work you hand in.

Write in dark blue or black pen.

You may use a pencil for any diagrams, graphs or rough work.

Do not use staples, paper clips, highlighters, glue or correction fluid.

DO **NOT** WRITE IN ANY BARCODES.

Answer **all** questions.

For each of the questions in Section A, you will be allowed to work with the apparatus for a maximum of 20 minutes. For the question in Section B, you will be allowed to work with the apparatus for a maximum of 1 hour.

You are expected to record all your observations as soon as these observations are made.

An account of the method of carrying out the experiments is **not** required.

At the end of the examination, fasten all your work securely together.

The number of marks is given in brackets [ ] at the end of each question or part question.

For Examiner's Use	
1	
2	
3	
4	
<b>Total</b>	

This document consists of **9** printed pages and **3** blank pages.



## Section A

Answer **all** questions in this section.

For  
Examiner's  
Use

- 1 *In this experiment, you will investigate the cooling of a thermometer in air and when surrounded by insulation.*

You have been provided with a supply of boiling water, a thermometer, a stand, boss and clamp to hold the thermometer, a beaker containing some tissues and a stopwatch.

- (a) Place the thermometer in the supply of boiling water. Allow the temperature on the thermometer to rise to approximately  $100^{\circ}\text{C}$ . Leave the thermometer for approximately 1 minute.

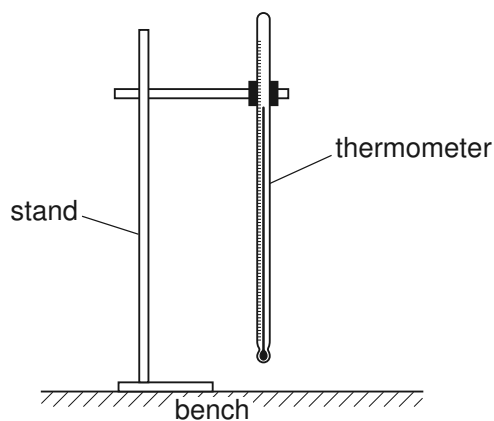

**Fig. 1.1**

Remove the thermometer and quickly support it in the clamp, as shown in Fig. 1.1.

- (b) When the temperature reaches  $60.0^{\circ}\text{C}$ , start the stopwatch and record the time  $t_1$  for the temperature to fall to  $50.0^{\circ}\text{C}$ .

$t_1 = \dots\dots\dots$  [1]

- (c) Repeat (a). Remove the thermometer and quickly support it in the clamp, as shown in Fig. 1.2.

For  
Examiner's  
Use

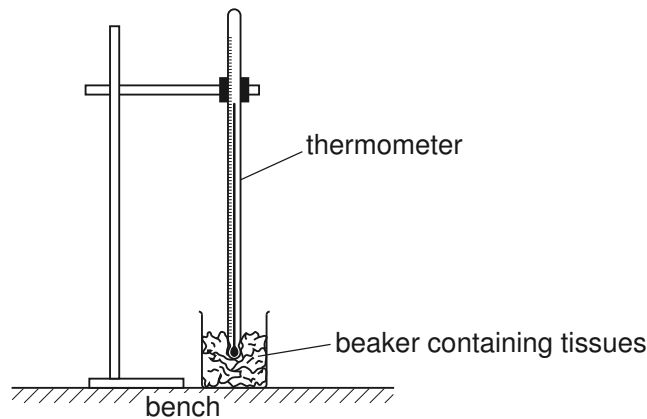

Fig. 1.2

The bulb of the thermometer should be placed in the middle of the tissues in the beaker.

- (d) When the temperature reaches 60.0°C, start the stopwatch and record the time  $t_2$  for the temperature to fall to 50.0°C.

$t_2 = \dots\dots\dots$  [1]

- (e) The average rate of fall of temperature is given by

$$\frac{\text{temperature fall}}{\text{time taken for the fall}}$$

- (i) Determine the average rate of fall of temperature for both the thermometer in air and the thermometer surrounded by tissues.

rate of fall of temperature in air = .....

rate of fall of temperature in tissues = .....

- (ii) State the effect that the tissues have had on the rate at which the temperature falls.

.....  
.....

[2]

- (f) Suggest why you were instructed to start and stop timing at the same temperature in both (b) and (d).

.....  
..... [1]

- 2 In this experiment, you will investigate the bending of a beam when masses are added to the beam.

For  
Examiner's  
Use

You have been provided with a metre rule, two metal support rods, a 0.500 kg mass, a loop of thread from which the mass may be suspended, a half-metre rule, a stand, boss and clamp to support the half-metre rule and a set square.

**Do not adjust the height of the support rods in this experiment.**

- (a) Place the metre rule on the support rods, as shown in Fig. 2.1.

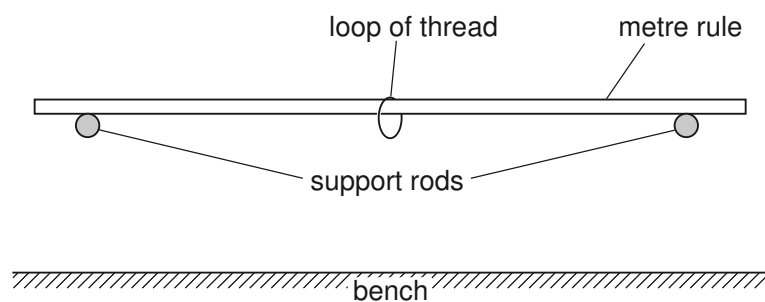

**Fig. 2.1**

The support rods should be at the 5.0 cm and 95.0 cm marks on the metre rule and the loop of thread should be at the 50.0 cm mark.

- (b) Clamp the half-metre rule vertically, with its scale facing towards you. The zero end of the half-metre rule should be uppermost. The half-metre rule should be placed behind the centre of the metre rule.
- (c) Suspend a mass  $M = 0.500$  kg from the centre of the metre rule, as shown in Fig. 2.2.

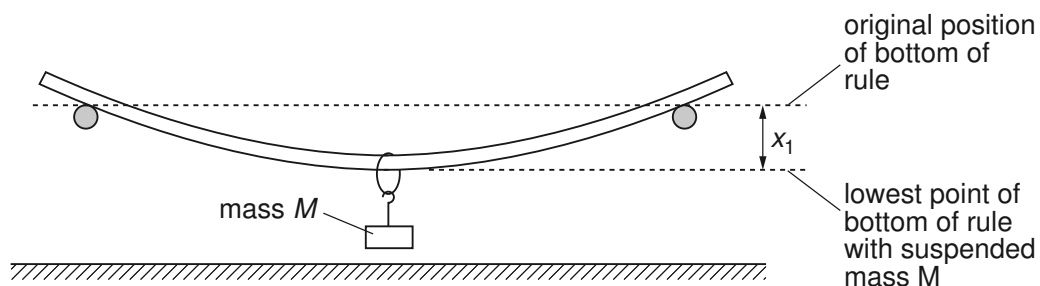

**Fig. 2.2**

Determine the vertical displacement  $x_1$  of the centre of the rule, as shown in Fig. 2.2. Show the two readings that you took from the half-metre rule in order to determine  $x_1$ .

$x_1 = \dots\dots\dots$  [2]

- (d) Repeat (c) with a mass  $M = 0.200$  kg. Determine the new displacement  $x_2$  of the centre of the metre rule. **Do not alter the position of the support rods when this new displacement is determined.**

For  
Examiner's  
Use

$x_2 = \dots\dots\dots$  [1]

- (e) It is suggested that the displacement  $x$  is directly proportional to the mass  $M$ .

- (i) Using your results from (c) and (d), determine two values of  $\left(\frac{x}{M}\right)$ .

first value of  $\left(\frac{x}{M}\right) = \dots\dots\dots$

second value of  $\left(\frac{x}{M}\right) = \dots\dots\dots$

- (ii) Comment on whether your results support the suggestion that  $x$  is directly proportional to  $M$ .

.....

.....

.....

.....

[2]

[Total: 5]

3 In this experiment, you will investigate a table-tennis ball rolling down a ramp from rest.

You have been provided with a table-tennis ball, a stopwatch, a ramp, two metre rules attached to the ramp and a pile of paper towels to stop the ball at the end of the ramp.

For  
Examiner's  
Use

(a) Determine the time  $t$  for the ball to travel a distance  $x = 0.800$  m, from rest to the bottom of the ramp.

$t = \dots\dots\dots$  [2]

(b) Explain how you ensured that the distance travelled by the ball was exactly 0.800 m.

.....  
.....  
.....  
..... [1]

(c) Calculate the acceleration  $a$  of the ball down the ramp, given that

$$a = \frac{2x}{t^2} .$$

$a = \dots\dots\dots$  [2]

[Total: 5]

## Section B

For  
Examiner's  
Use

- 4 In this experiment, you will investigate the power dissipated in resistors that are connected into a circuit.

You have been provided with a circuit containing a gap between two points labelled A and B. In addition to the circuit, you have two  $100\ \Omega$  resistors, two  $1000\ \Omega$  resistors and some extra connecting leads.

- (a) In the space below, draw a circuit diagram of the circuit that has been set up for you. Label points A and B on your circuit.

[2]

- (b) Connect one of the  $100\ \Omega$  resistors between points A and B.

- (i) Close the switch and measure the potential difference  $V$  between points A and B.

$V =$  .....

- (ii) Calculate the power  $P$  dissipated in the resistor, using the equation

$$P = \frac{V^2}{R}$$

where  $R$  is the resistance between points A and B.

$P =$  .....

[2]

- (c) (i) Using the two  $100\ \Omega$  resistors in both a series and a parallel combination between A and B, obtain two further values for  $V$ .

$V$  for series combination = .....

$V$  for parallel combination = .....

- (ii) Two  $100\ \Omega$  resistors connected in series have a total resistance of  $200\ \Omega$ . Two  $100\ \Omega$  resistors connected in parallel have a total resistance of  $50\ \Omega$ . Record your values of  $V$  obtained in (b)(i) and (c)(i) in Fig. 4.1.

$R/\Omega$	$V/$	$P/$
100		
200		
50		

Fig. 4.1

- (iii) Calculate the power  $P$  dissipated in each resistor arrangement and record these in Fig. 4.1. Add units to the column headings.
- (iv) Remove the  $100\ \Omega$  resistors from between points A and B and connect one of the  $1000\ \Omega$  resistors between these points. Measure  $V$  and calculate  $P$  for the  $1000\ \Omega$  resistor. Record these values in Fig. 4.1.
- (v) Using the two  $1000\ \Omega$  resistors in both a series and a parallel combination between A and B, obtain two further sets of values of  $R$ ,  $V$  and  $P$ . Record all your values in Fig. 4.1.
- [5]
- (d) Using the grid opposite, plot a graph of  $P/W$  on the  $y$ -axis against  $R/\Omega$  on the  $x$ -axis.
- [4]
- (e) Use your graph to determine the value of  $R$  that gives the maximum power dissipation.

$R = \dots\dots\dots$  [2]

For  
Examiner's  
Use



For  
Examiner's  
Use

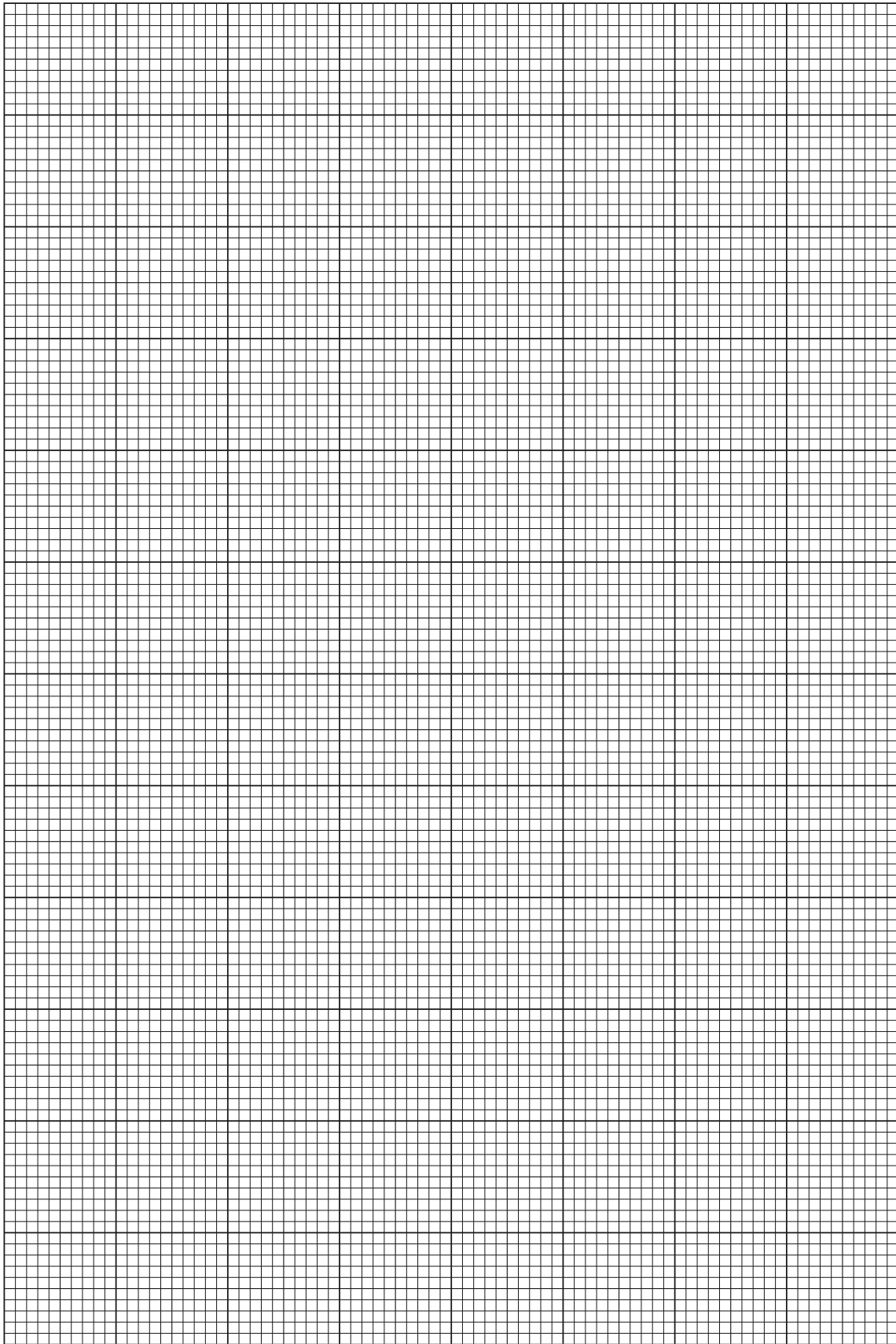

[Total: 15]





**BLANK PAGE**

---

Permission to reproduce items where third-party owned material protected by copyright is included has been sought and cleared where possible. Every reasonable effort has been made by the publisher (UCLES) to trace copyright holders, but if any items requiring clearance have unwittingly been included, the publisher will be pleased to make amends at the earliest possible opportunity.

University of Cambridge International Examinations is part of the Cambridge Assessment Group. Cambridge Assessment is the brand name of University of Cambridge Local Examinations Syndicate (UCLES), which is itself a department of the University of Cambridge.